



Systems and Technology Group

All About the Cell Processor

H. Peter Hofstee, Ph. D.
IBM Systems and Technology Group
SCEI/Sony Toshiba IBM Design Center
Austin, Texas

Acknowledgements

- **Cell is the result of a deep partnership between SCEI/Sony, Toshiba, and IBM**
- **Cell represents the work of more than 400 people starting in 2001**
- **More detailed papers on the Cell implementation and the SPE micro-architecture can be found in the ISSCC 2005 proceedings**

Agenda

- **Trends in Processors and Systems**
- **Cell Processor Overview**
- **Aspects of the Implementation**
- **Power Efficient Architecture**

Trends in Microprocessors and Systems

Processor Performance over Time

(Game processors take the lead on media performance)

Flops (SP)

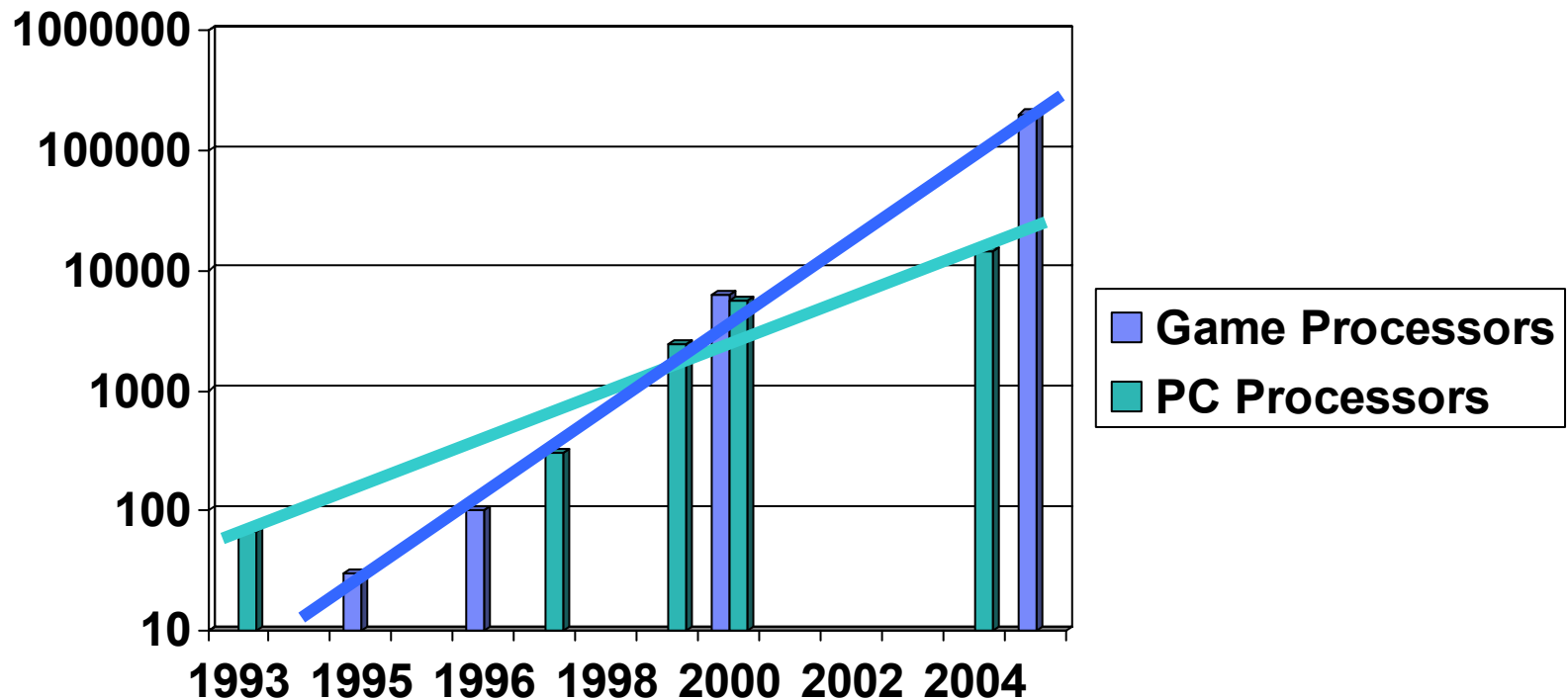

System Trends toward Integration

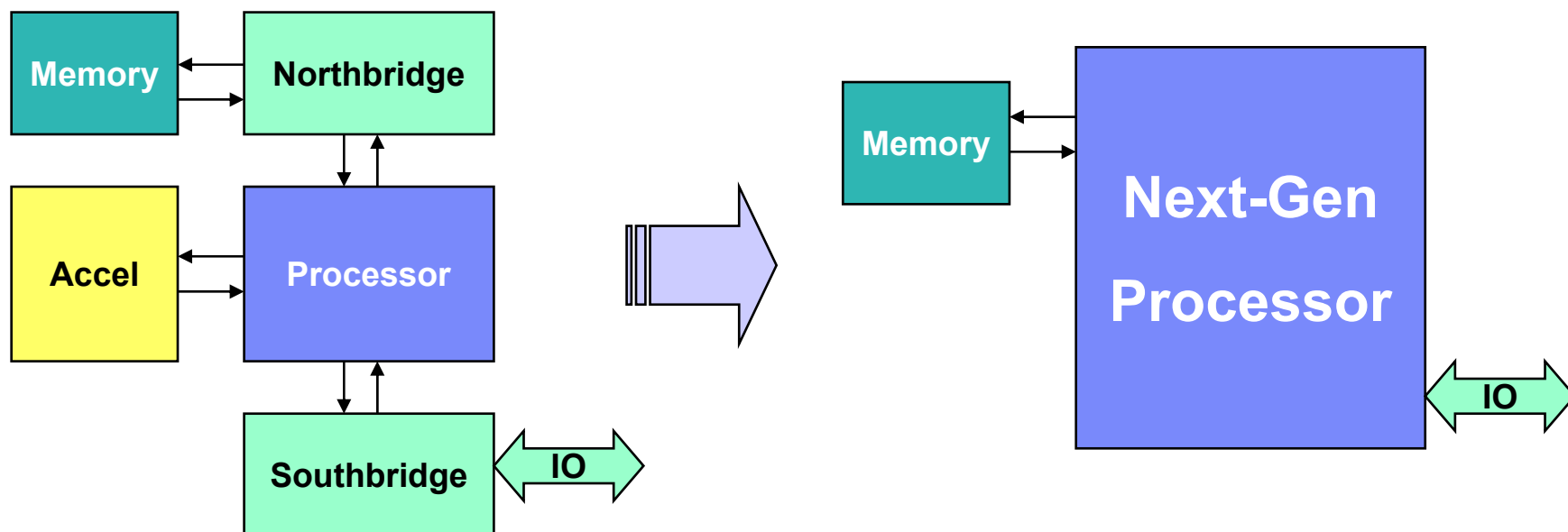

- Implied loss of system configuration flexibility
- Must compensate with generality of acceleration function to maintain market size.

Next Generation Processors address Programming Complexity and Trend Towards Programmable Offload Engines with a Simpler System Alternative

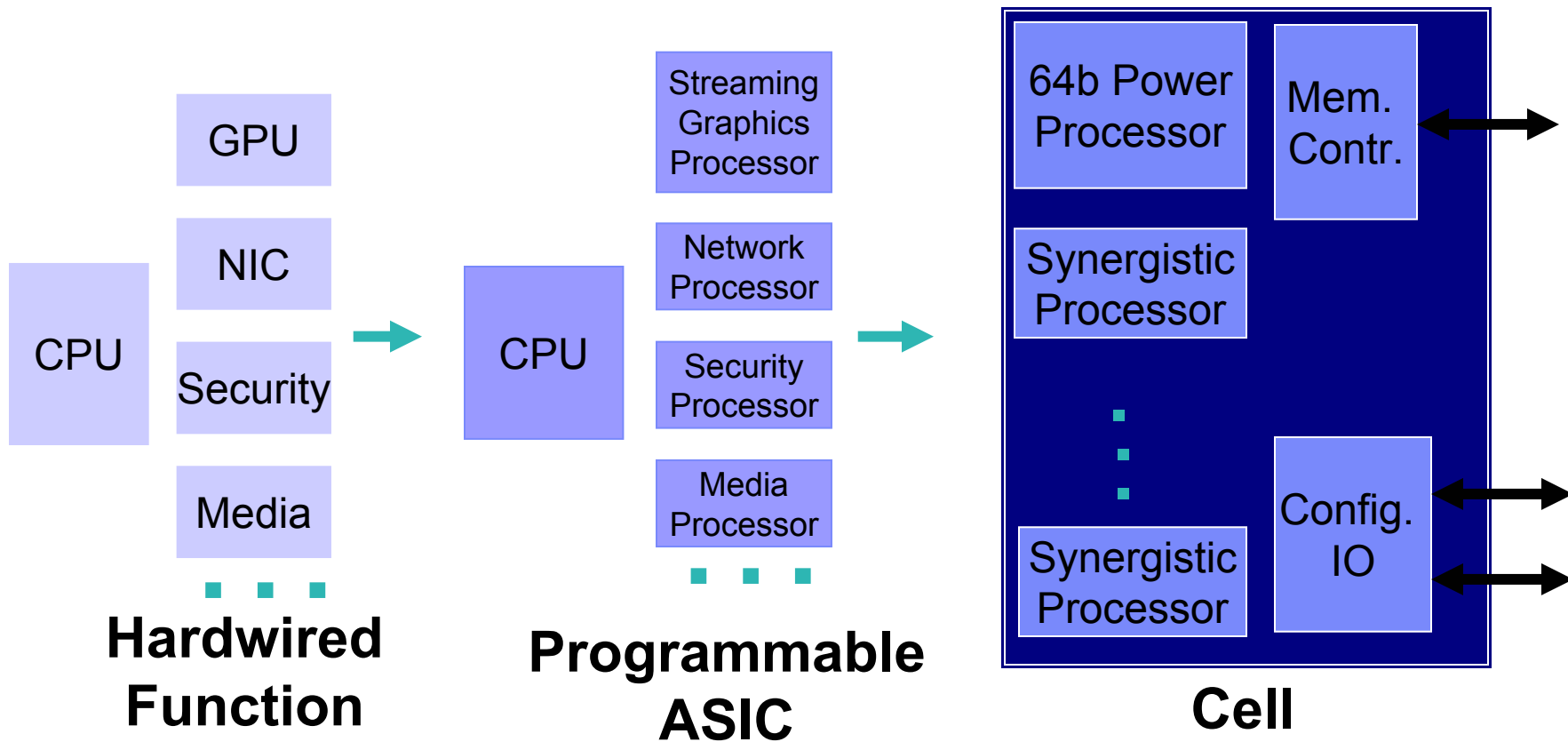

Performance Limiters in Conventional Microprocessors

- **Memory Wall**
 - Latency induced bandwidth limitations
- **Power Wall**
 - Must improve efficiency and performance equally
- **Frequency Wall**
 - Diminishing returns from deeper pipelines
(can be negative if power is taken into account)

Cell Overview

Cell Goals

- **Outstanding performance, especially on game/multimedia applications.**
- **Real time responsiveness to the user and the network.**
- **Applicable to a wide range of platforms.**
- **Support introduction in systems in 2005.**

Cell Concept

- **Compatibility with 64b Power Architecture™**
 - Builds on and leverages IBM investment and community
- **Increased efficiency and performance**
 - Non Homogenous Coherent Chip Multiprocessor
 - High design frequency, low operating voltage
 - Streaming DMA architecture attacks “Memory Wall”
 - Highly optimized implementation
- **Interface between user and networked world**
 - Image rich information, virtual reality
 - Flexibility and security
- **Multi-OS support, including RTOS/non-RTOS**
 - Combine real-time and non-real time worlds

Cell Chip Block Diagram

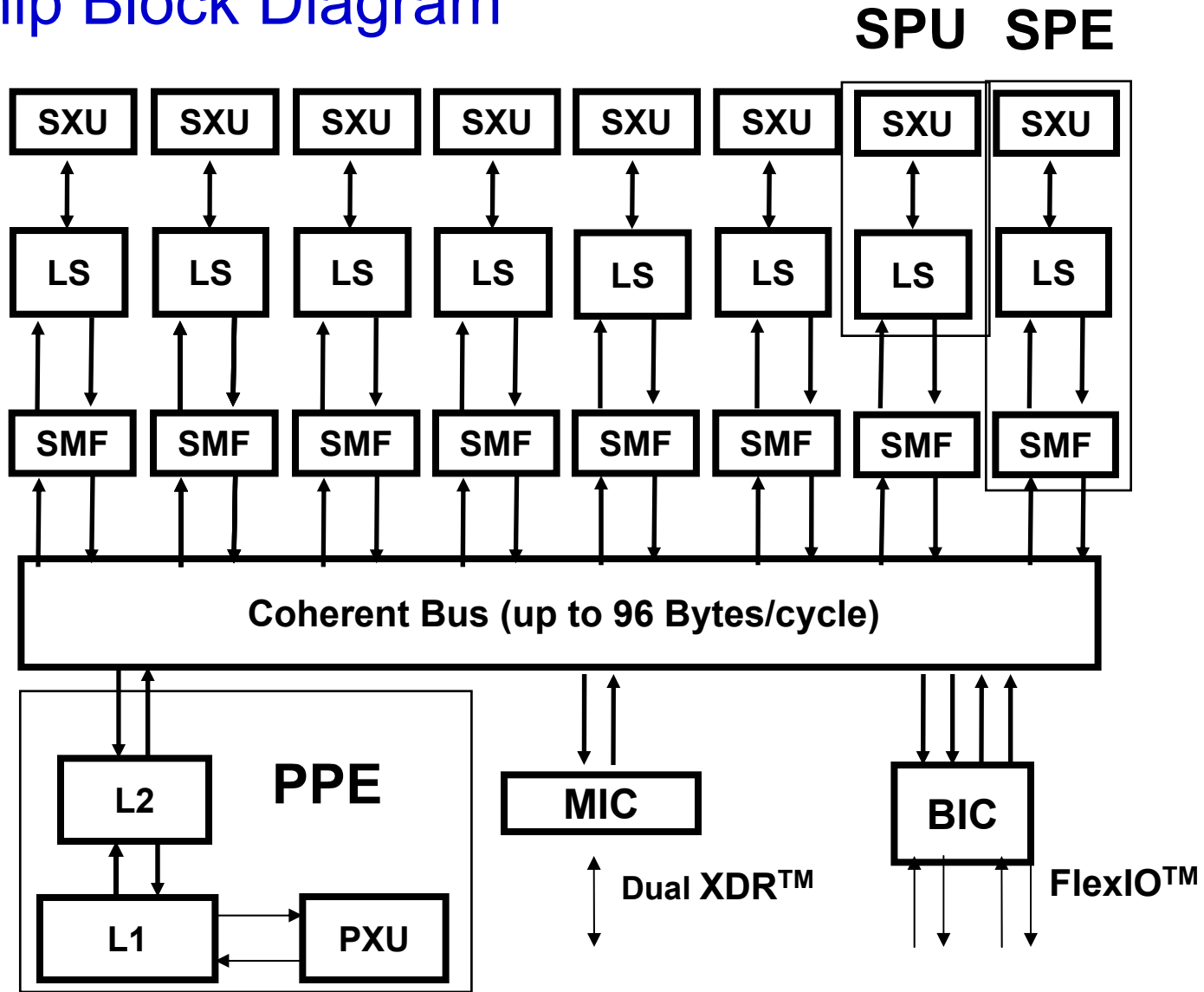

What is a Synergistic Processor? (and why is it efficient?)

- **Local Store “is” large 2nd level register file / private instruction store instead of cache**
 - Asynchronous transfer (DMA) to **shared memory**
 - Frontal attack on the Memory Wall
- **Media Unit turned into a Processor**
 - Unified (large) Register File
 - 128 entry x 128 bit
- **Media & Compute optimized**
 - One context
 - **SIMD architecture**

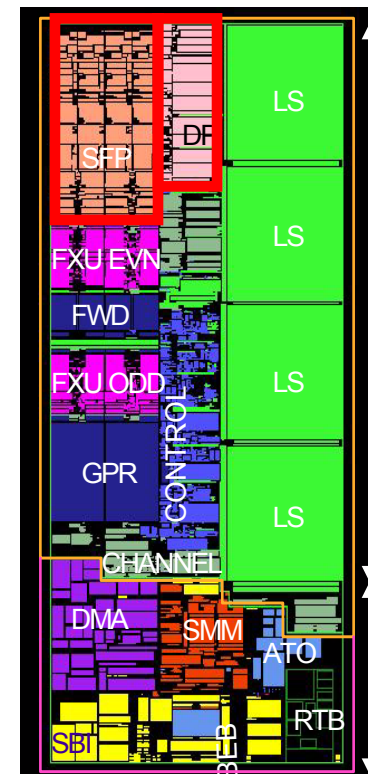

Coherent Offload Model

- **DMA into and out of Local Store equivalent to Power core loads & stores**
- **Governed by Power Architecture page and segment tables for translation and protection**
- **Shared memory model**
 - Power architecture compatible addressing
 - MMIO capabilities for SPEs
 - Local Store is mapped (alias) allowing LS to LS DMA transfers
 - DMA equivalents of locking loads & stores
 - OS management/virtualization of SPEs
 - Pre-emptive context switch is supported (but not efficient)

One approach to programming Cell

- **Single Source Compiler**

- Auto parallelization (treat target Cell as an SMP)
- Auto SIMD-ization (SIMD-vectorization)
- Compiler management of Local Store as 2nd level register file / SW managed cache (I&D)
 - Most Cell unique piece

- **Optimization**

- OpenMP pragmas
- Vector.org SIMD intrinsics
- Data/Code partitioning
- Streaming / pre-specifying code/data use

- **Prototype Single Source Compiler Developed in IBM Research**

Cell Implementation Aspects

SPE BLOCK DIAGRAM

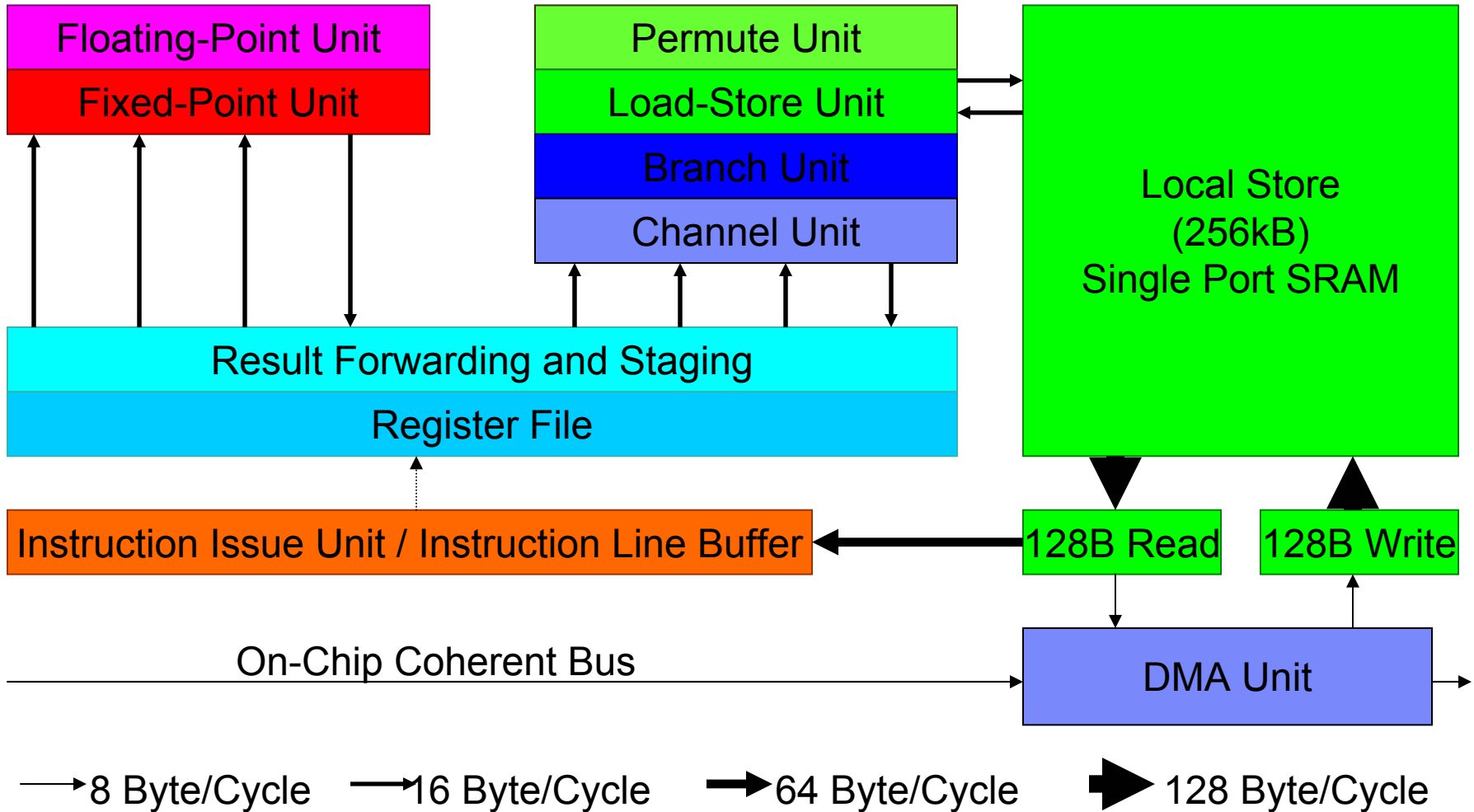

SPE PIPELINE FRONT END

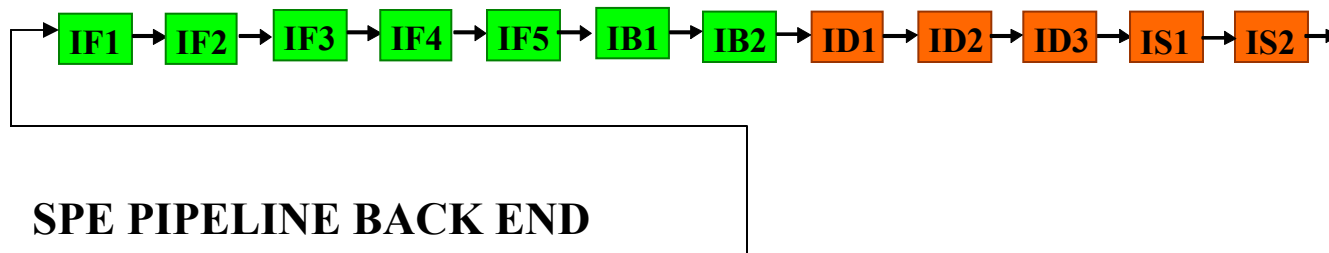

SPE PIPELINE BACK END

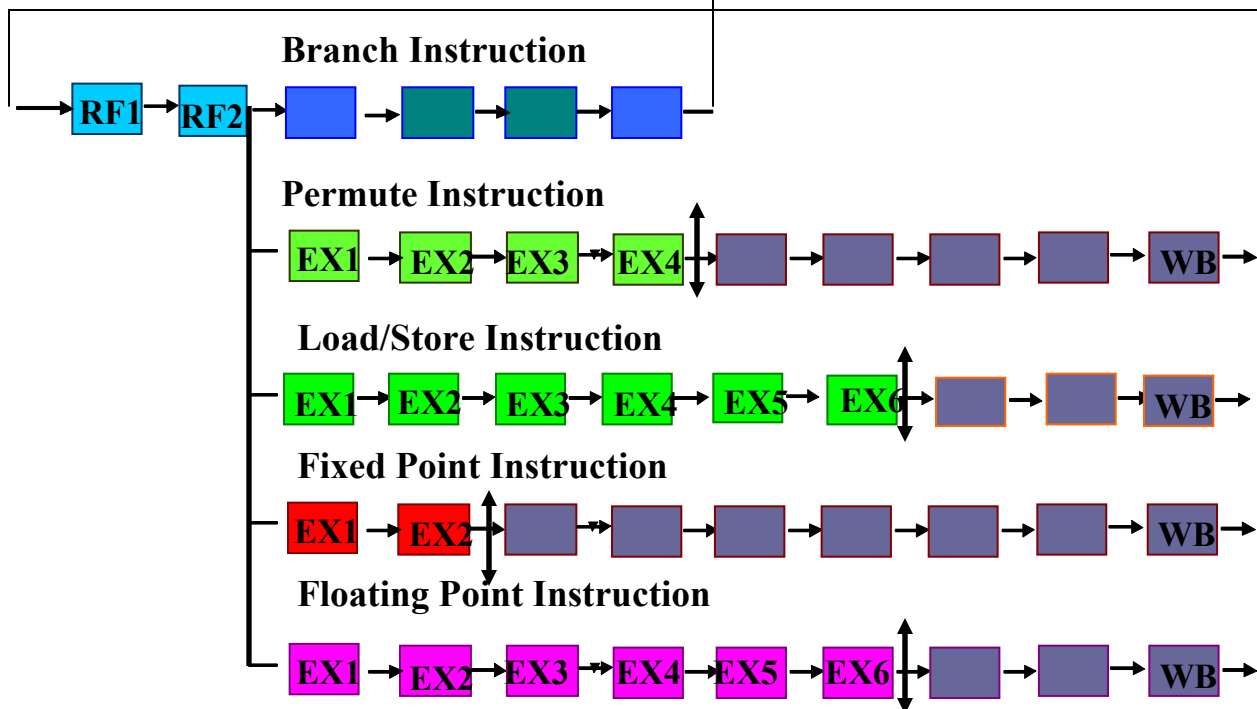

- IF Instruction Fetch
- IB Instruction Buffer
- ID Instruction Decode
- IS Instruction Issue
- RF Register File Access
- EX Execution
- WB Write Back

PPE BLOCK DIAGRAM

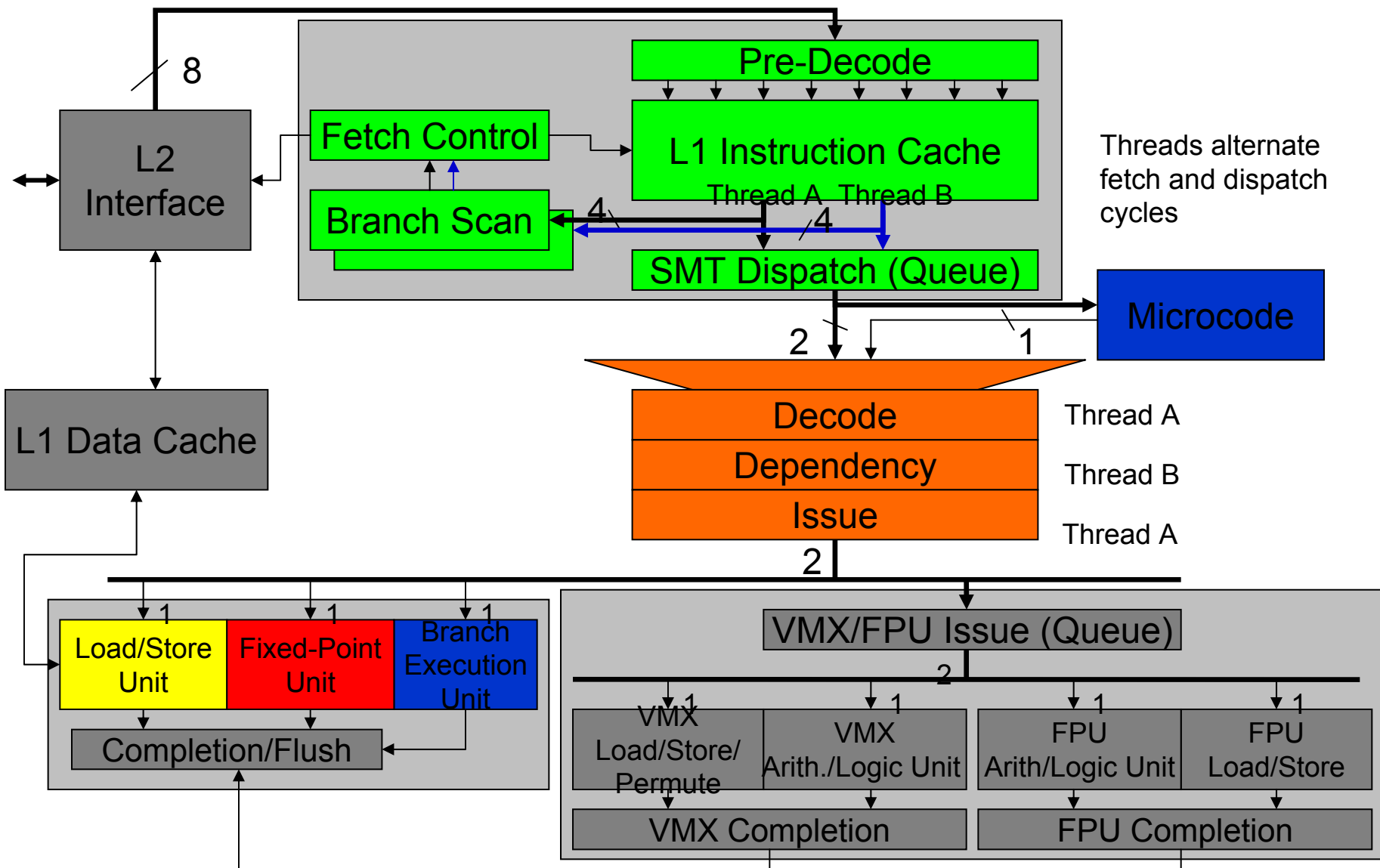

PPE PIPELINE FRONT END

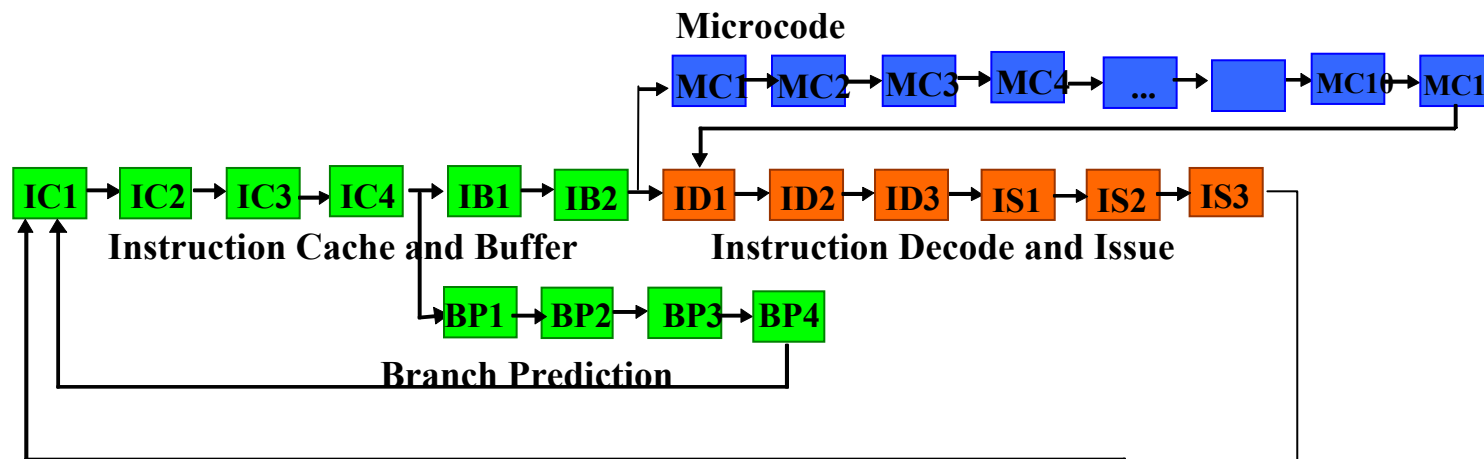

PPE PIPELINE BACK END

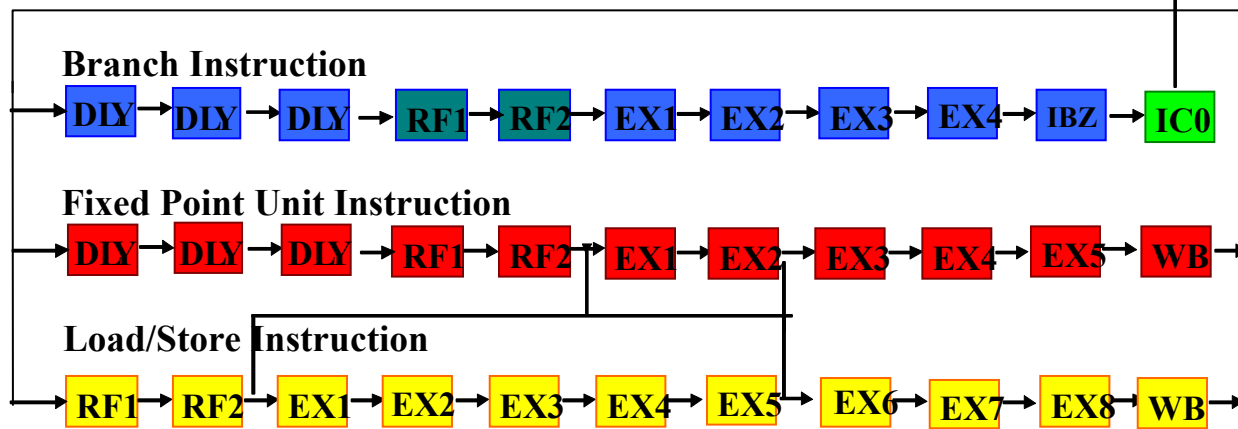

- IC Instruction Cache
- IB Instruction Buffer
- BP Branch Prediction
- MC Microcode
- ID Instruction Decode
- IS Instruction Issue
- DLY Delay Stage
- RF Register File Access
- EX Execution
- WB Write Back

Cell Processor

- ~250M transistors
- ~235mm²
- Top frequency >4GHz
- 9 cores, 10 threads
- > 256 GFlops (SP) @4GHz
- > 26 GFlops (DP) @4GHz
- Up to 25.6GB/s memory B/W
- Up to 75 GB/s I/O B/W
- ~400M\$(US) design investment

Cell Broadband Engine Processor

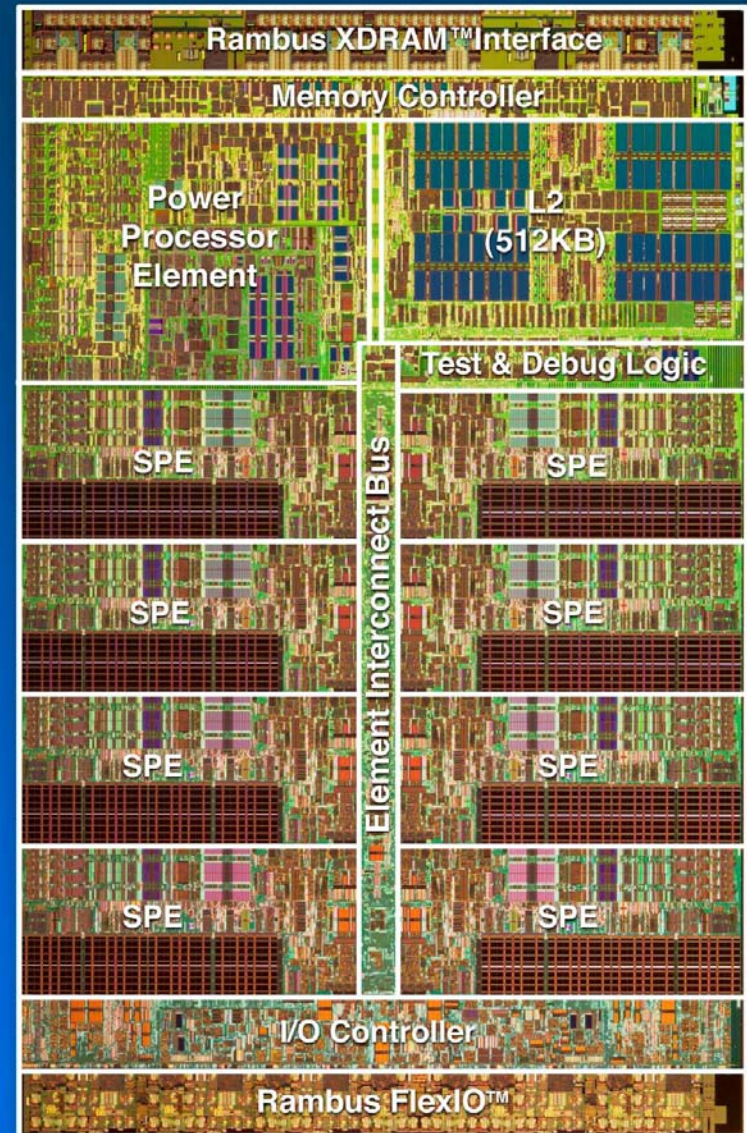

First pass hardware **measurement** in the Lab - Nominal Voltage = 1V

Hardware Performance Measurement (85°C)

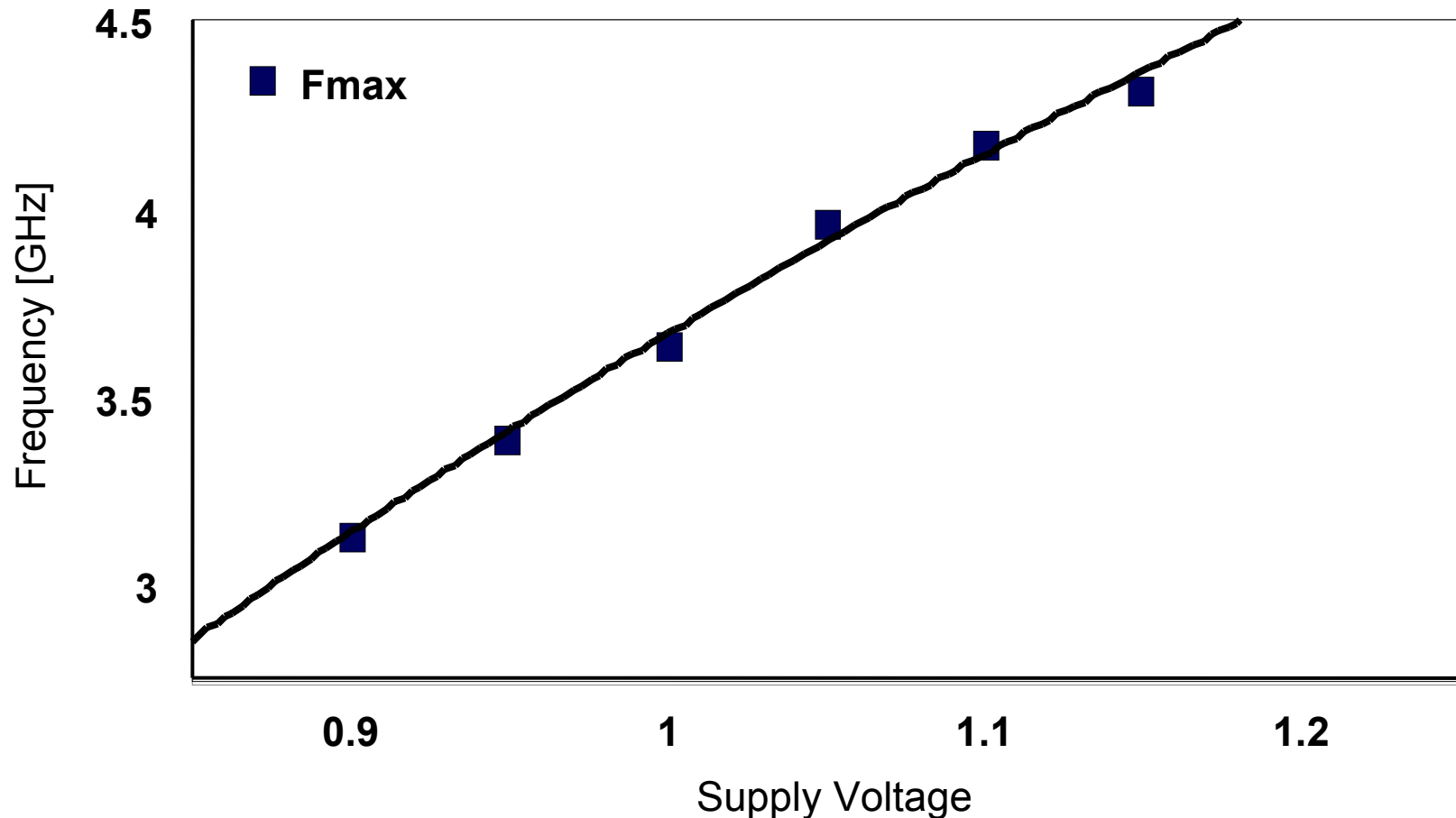

Cell Processor Configurable I/O

- Direct Attach XDR
- Two I/O interfaces
 - Configurable number of Bytes
 - Coherent or I/O Protection

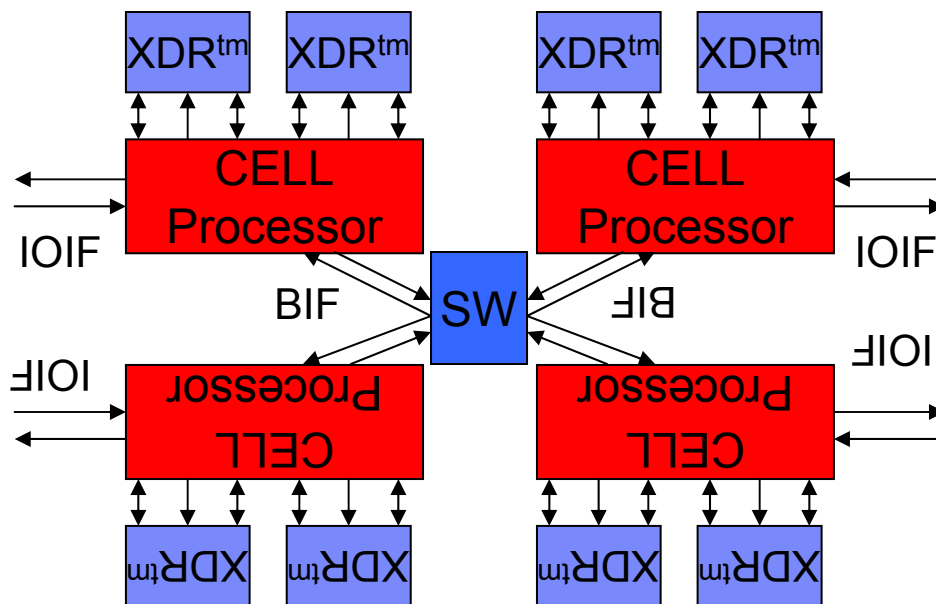
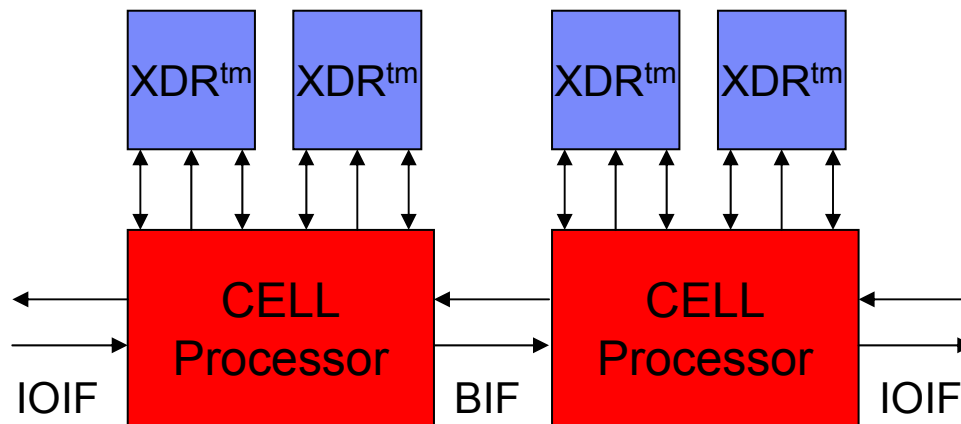
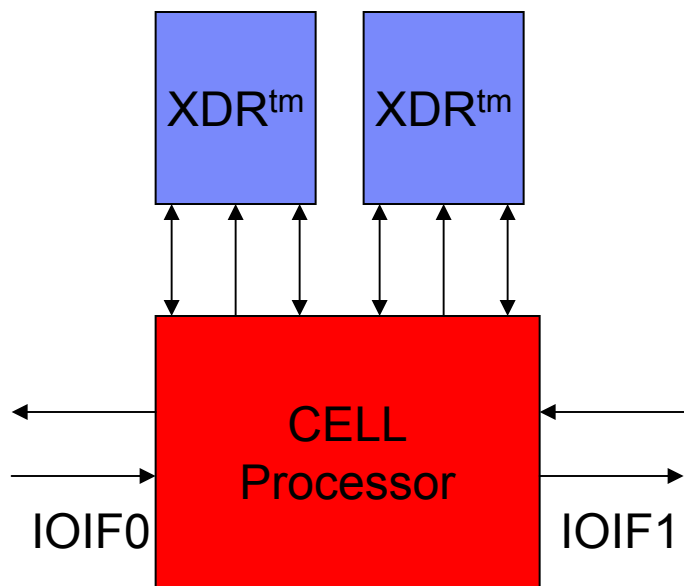

Power Efficient Architecture

Power Efficient Architecture and the BE

- **Non-Homogeneous Coherent Multi-Processor**
 - Data-plane/Control-plane specialization
 - More efficient than homogeneous SMP
- **3-level model of Memory**
 - Bandwidth without (inefficient) speculation
 - High-bandwidth .. Low power

Power Efficient Architecture and the SPE

- **Power Efficient ISA allows Simple Control**
 - Single mode architecture
 - No cache
 - Branch hint
 - Large unified register file
 - Channel Interface
- **Efficient Microarchitecture**
 - Single port local store
 - Extensive clock gating
- **Efficient implementation**
 - See Cool Chips paper by O. Takahashi et al. and T. Asano et al.

Cell BE Processor Example Application Areas

- Cell excels at processing of rich media content in the context of broad connectivity
 - Digital content creation (games and movies)
 - Game playing and game serving
 - Distribution of dynamic, media rich content
 - Imaging and image processing
 - Image analysis (e.g. video surveillance)
 - Next-generation physics-based visualization
 - Video conferencing
 - Streaming applications (codecs etc.)
 - Physical simulation & science
- Cell is an excellent match for any applications that require:
 - Parallel processing
 - Real time processing
 - Graphics content creation or rendering
 - Pattern matching
 - High-performance SIMD capabilities

Cell Summary

- **Cell ushers in a new era of leading edge processors optimized for digital media and entertainment**
- **Responsiveness to the human user and the network are key drivers for Cell**
- **New levels of performance and power efficiency beyond what is achieved by PC processors**
- **Cell will enable entirely new classes of applications, even beyond those we contemplate today**