



IBM T.J. Watson Research Center

# The CHAMPS System: Standards-based Autonomic Change Management with WS-BPEL, WS-Agreement and Solution Install

Alexander Keller, [alexk@us.ibm.com](mailto:alexk@us.ibm.com)



# IT Infrastructure Library: Change Management

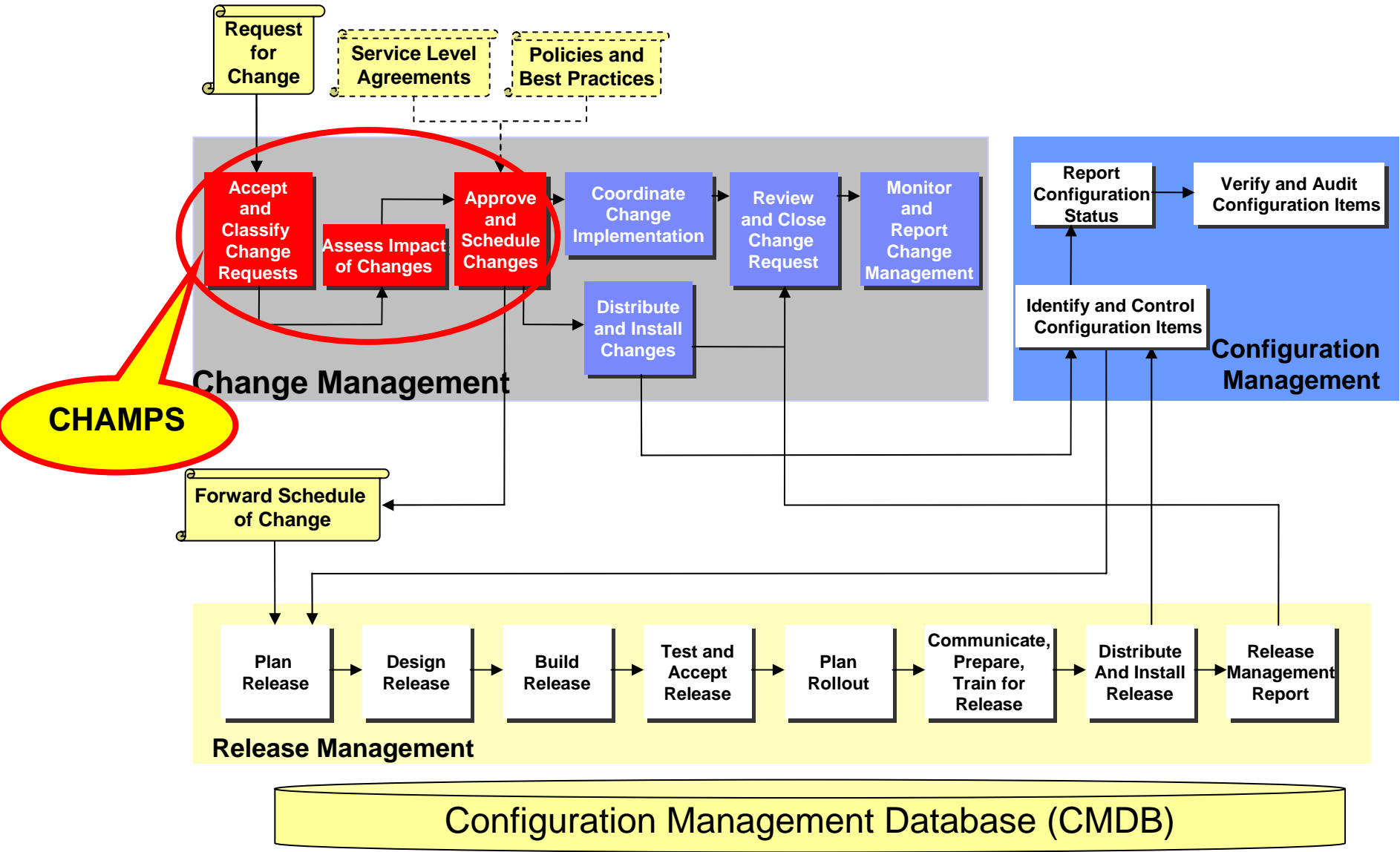

# CHAMPS: Standards-based Change Management

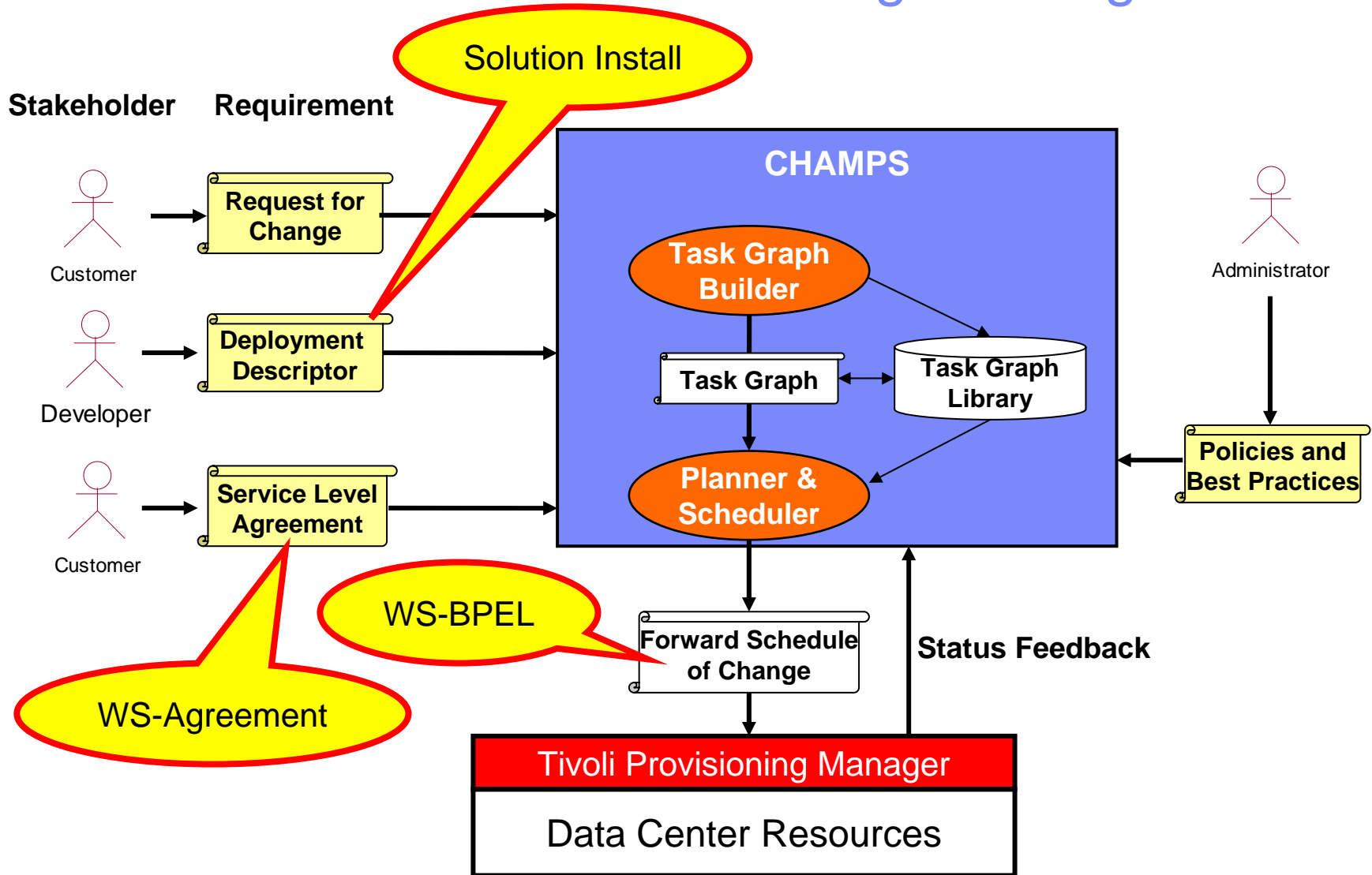

# Example: DB2/WAS Provisioning for SPECJAppServer2004



## CHAMPS Goal:

- Automatic construction of BPEL workflows from
  - RFC
  - Solution Install Deployment Descriptors
  - Cost/profit considerations (SLAs)
  - Constrained Resources
- Addresses the P/E parts of MAPE loop

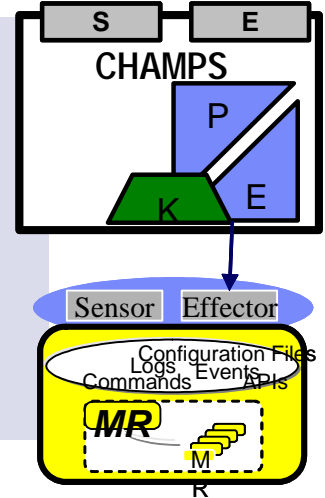

## DB2:

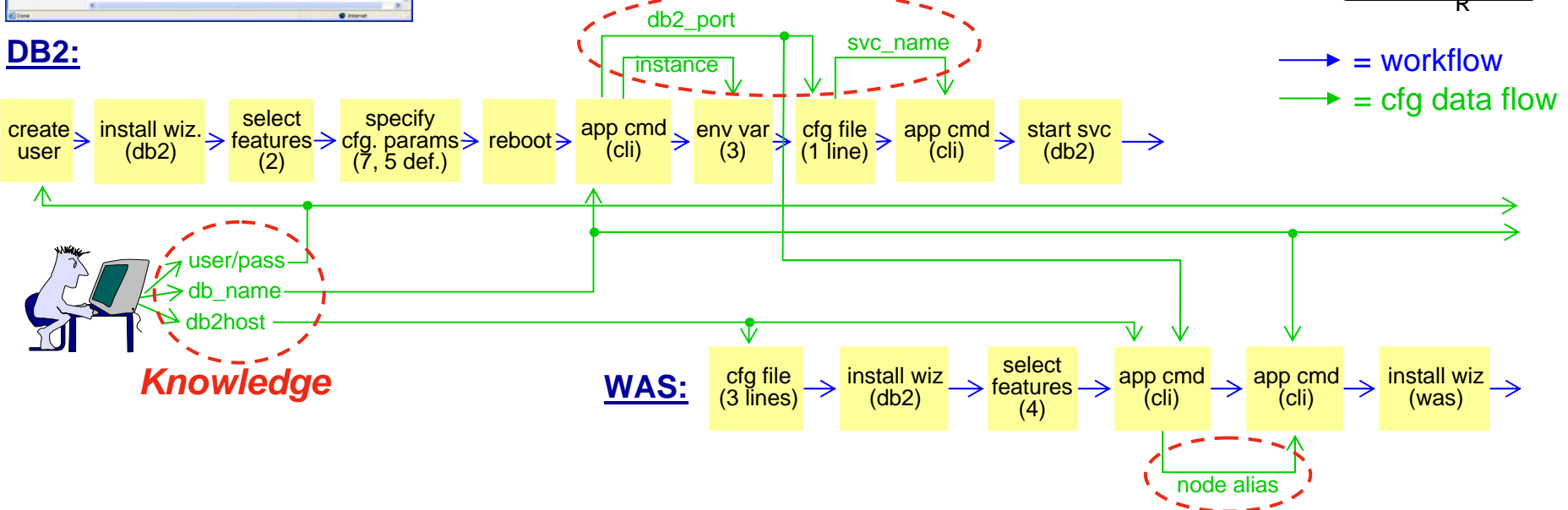

# Step 1: Specify SLAs in WS-Agreement

| wsag:IdName   | wsag:ServiceScope | wsag:Service...   | wsag:BusinessValueList  |
|---|-------------------|-------------------|---|
| 1 ResourcesAvailableFrom_900am_To_500pm_p_rbed_every_Minute | wsag:ServiceScope | 09:00:00-17:00:00 | <ul style="list-style-type: none"> <li>wsag:Penalty                             <ul style="list-style-type: none"> <li>wsag:AssessmentInterval                                     <ul style="list-style-type: none"> <li>wsag:ValueUnit: USD</li> <li>wsag:ValueExpr...: 5.00</li> <li>wsag:TimeInter...: PT1M</li> </ul> </li> <li>wsag:AssessmentInterval                                     <ul style="list-style-type: none"> <li>wsag:ValueUnit: USD</li> <li>wsag:ValueExpr...: 50.00</li> <li>wsag:TimeInter...: PT10M</li> </ul> </li> <li>wsag:AssessmentInterval                                     <ul style="list-style-type: none"> <li>wsag:ValueUnit: USD</li> <li>wsag:ValueExpr...: 500.00</li> <li>wsag:TimeInter...: PT30M</li> </ul> </li> <li>wsag:AssessmentInterval                                     <ul style="list-style-type: none"> <li>wsag:ValueUnit: USD</li> <li>wsag:ValueExpr...: 5000.00</li> <li>wsag:TimeInter...: PT1H</li> </ul> </li> </ul> </li> <li>wsag:Reward                             <ul style="list-style-type: none"> <li>wsag:AssessmentInterval                                     <ul style="list-style-type: none"> <li>wsag:ValueUnit: USD</li> <li>wsag:ValueExpr...: 10</li> <li>wsag:TimeInter...: PT1M</li> </ul> </li> <li>wsag:AssessmentInterval                                     <ul style="list-style-type: none"> <li>wsag:ValueUnit: USD</li> <li>wsag:ValueExpr...: 100</li> <li>wsag:TimeInter...: P1D</li> </ul> </li> </ul> </li> </ul> |
| 2 ResourcesAvailableFrom_5pm_to_2am_p_rbed_every_Minute     | wsag:ServiceScope | 17:00:00-02:00:00 | wsag:BusinessValueList  |
| 3 ResourcesInMaintenanceFrom_2am_to_3am_p_rbed_every_Minute | wsag:ServiceScope | 02:00:00-03:00:00 | wsag:BusinessValueList  |
| 4 ResourcesAvailableFrom_3am_to_9am_p_rbed_every_Minute     | wsag:ServiceScope | 03:00:00-09:00:00 | wsag:BusinessValueList  |

Time intervals

Costs and profits are specified the same way

5 \$ per Minute

Additional penalties if not resolved within a certain time period

Additional bonus for continuous uptime

## Step 2: Solution Install: Expressing Dependencies between the SPECjAppServer2004 Components and their Middleware

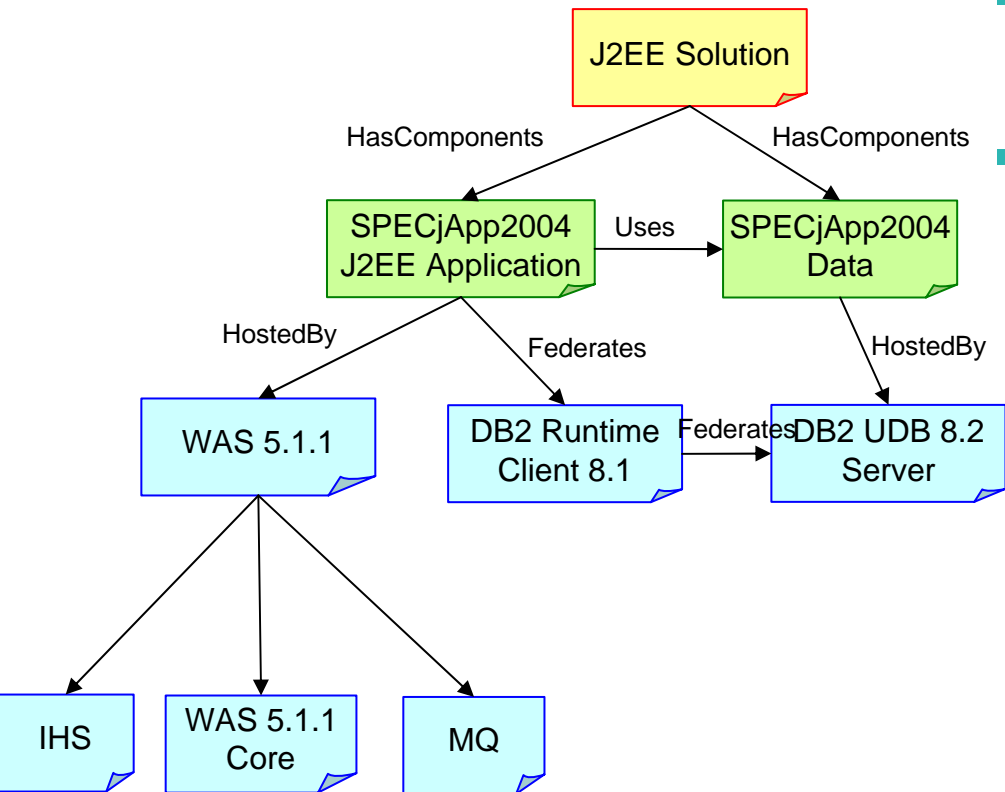

- **Customer wants to provision a J2EE Solution**

- **3 Layers:**

- Overall Solution

- Defined by Solution Architect

- Application Components

- Customer specific (here: SPECjAppServer2004)

- Middleware Stack

- Shrink-wrapped Software Components

# Step 3: Generate Forward Schedule of Change in WS-BPEL

Installable Units (IUs) for WAS 5.1

Parallel deployment of DB2 and WAS

Temporal Constraints when output data from DB2 is needed for WAS configuration

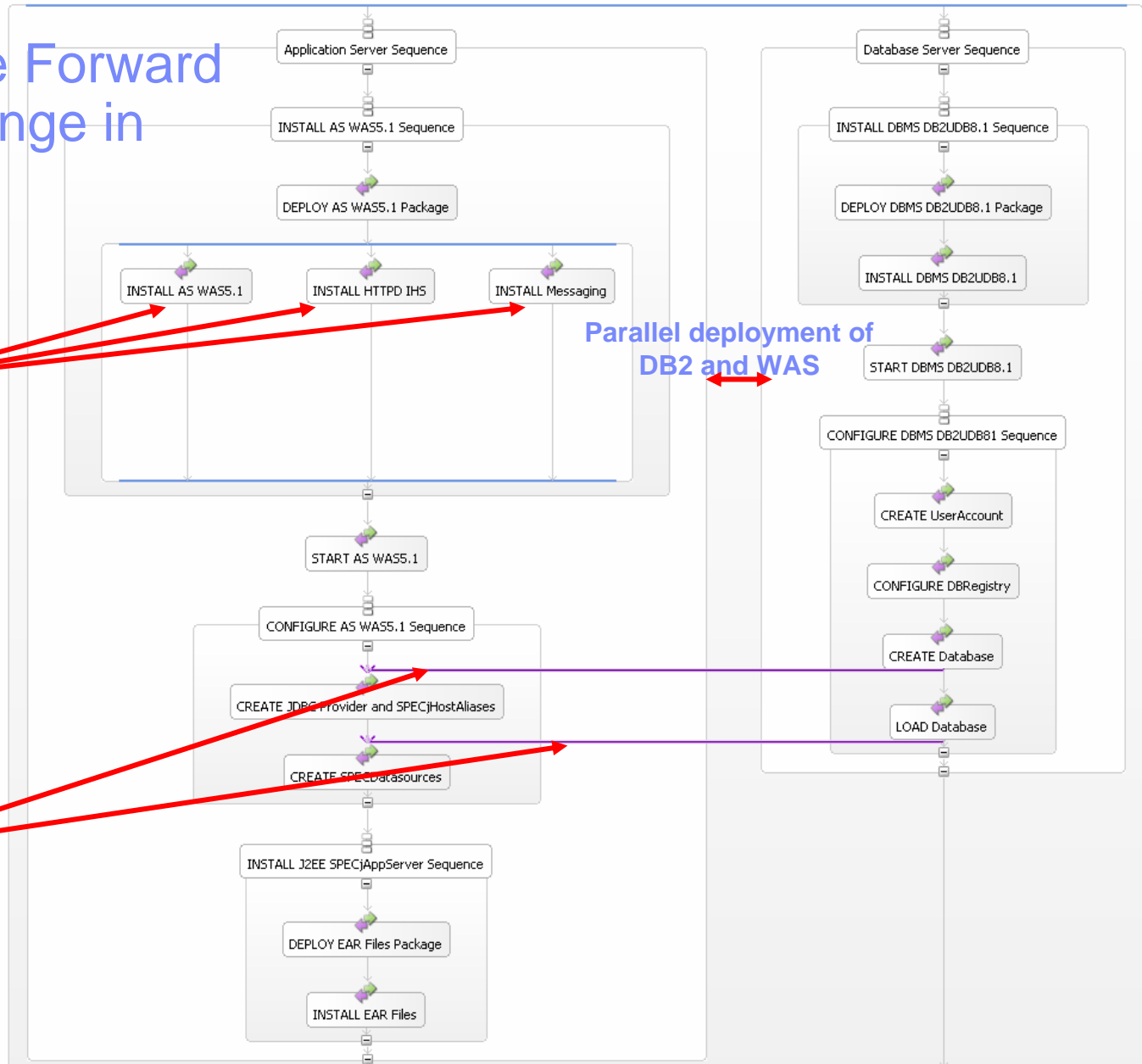

# SPECjAppServer2004 Solution Provisioning

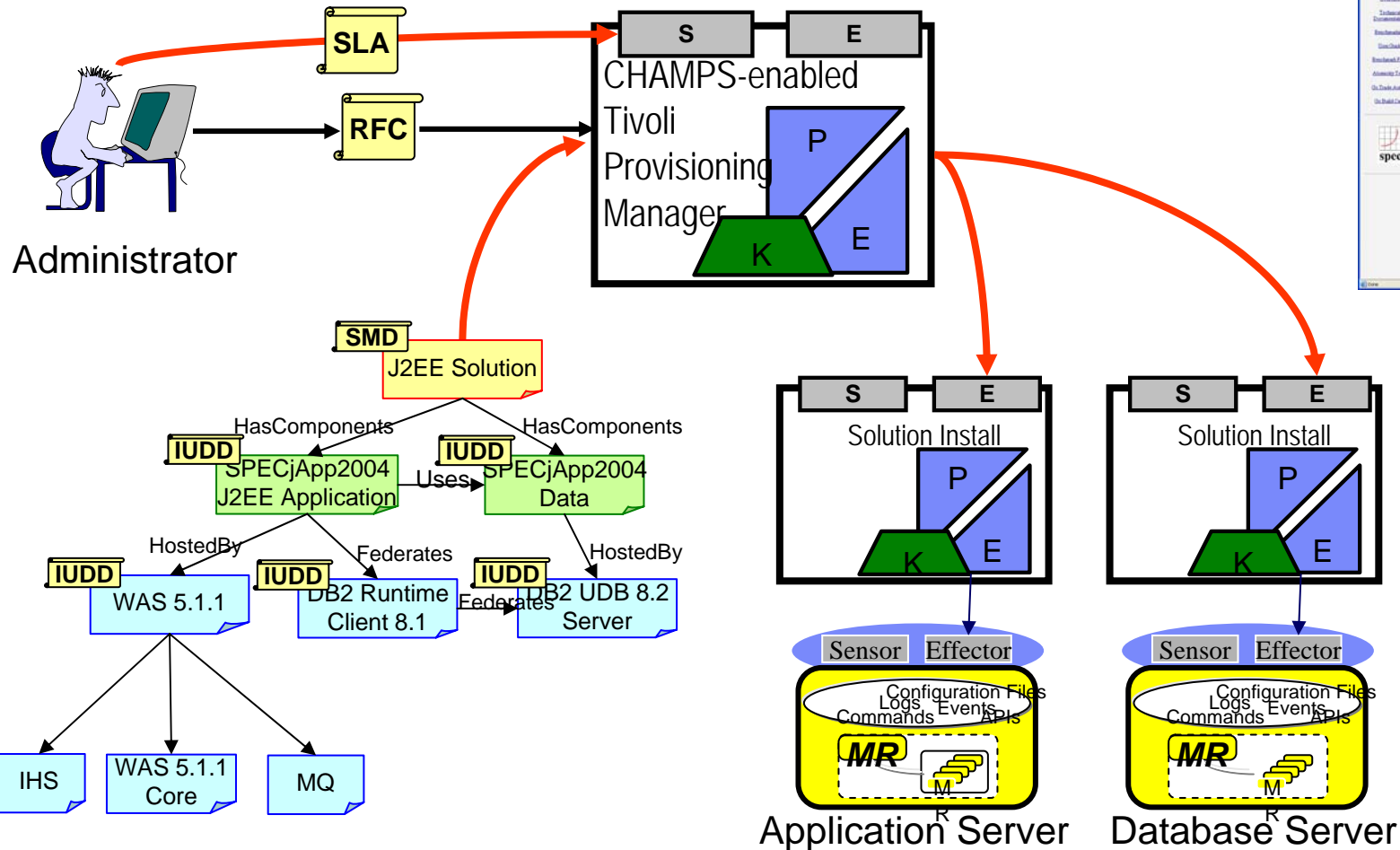

# Solution Provisioning Prototype

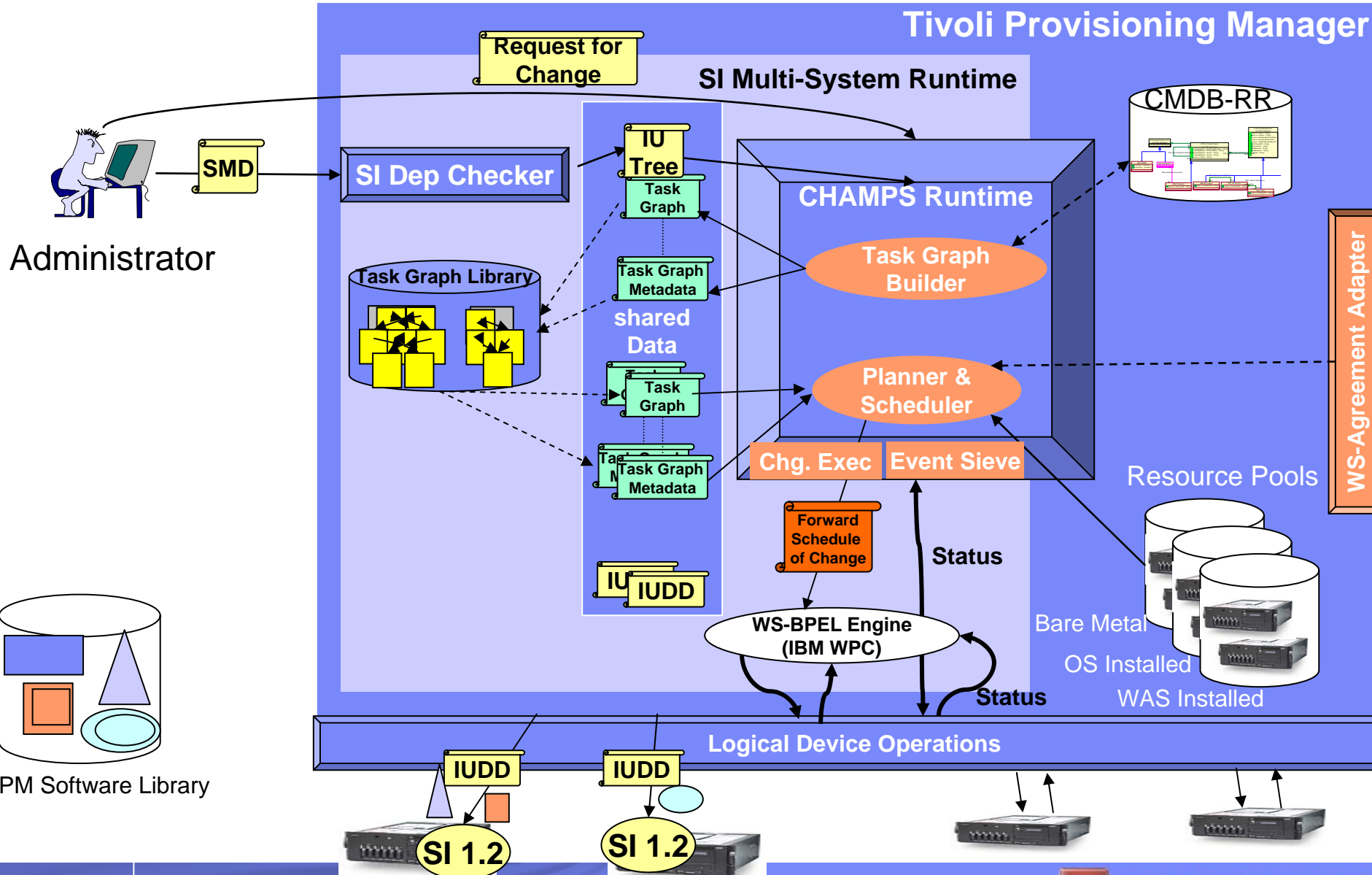

# CHAMPS Evaluation & Leverage of Standards

| Activity type  | Average times [minutes.seconds] for: |         |                |
|--|--------------------------------------|---------|----------------|
|  | DB2 UDB 8.1 / RT Client              | WAS 5.1 | SPECjAppServer |
| Deployment (file transfer / unpack of install image)   | 5.56 / 1.14                          | 5.52    | 1.34           |
| Installation   | 6.42 / 1.34                          | 14.31   | 4.54           |
| Start  | 0.16                                 | 0.48    | n/a            |
| Configuration (incl. DB creation and loading of data)  | 5.28                                 | 1.36    | n/a            |
| <b>Total time (strictly sequential, no think time)</b> | <b>50 min 25 sec.</b>                |         |                |
| <b>Total time (CHAMPS workflow)</b>                    | <b>34 min 00 sec.</b>                |         |                |
| <b>Total savings (time seq.–time CHAMPS)/time seq.</b> | <b>16 min 25 sec (~33%)</b>          |         |                |

- SPECjAppServer2004 Provisioning: CHAMPS yields 33% time savings**
  - Strictly sequential (no awareness of Dependencies): ~50 Min.
  - CHAMPS workflow (exploiting opportunities for Concurrency): ~34 Min.
- WS-Agreement works well for expressing flexible cost and profit functions**
  - Needed as input parameters for Planner & Scheduler to guide resource assignment
- Solution Install provides application dependency information**
  - Facilitates creation of Provisioning Workflows
  - Standardized in new OASIS Solution Deployment Descriptor (SDD) working group
- WS-BPEL is a viable option for expressing change management workflows**
  - Concurrent execution, Deadlines, Links across different workflows

## More Information

- **CHAMPS Architecture & Optimization Problem Formulation**
  - Alexander Keller et al., ***The CHAMPS System: Change Management with Planning and Scheduling***, Proc. NOMS 2004 – 8<sup>th</sup> IEEE/IFIP Network Operations and Management Symposium, April 2004, IEEE Press
- **WS-BPEL for Change Management**
  - Alexander Keller, Remi Badonnel. ***Automating the Provisioning of Application Services with the BPEL4WS Workflow Language***, Proc. DSOM 2004: 15<sup>th</sup> IFIP/IEEE International Workshop on Distributed Systems: Operations & Management, November 2004, Springer LNCS
- **Quantitative Evaluation of CHAMPS**
  - Aaron B. Brown, Alexander Keller, Joseph L. Hellerstein. ***A Model of Configuration Complexity and Its Application to a Change Management System***, Proc. IM 2005 – 9<sup>th</sup> IFIP/IEEE International Symposium on Integrated Network Management, May 2005, IEEE Press



Best  
Paper  
Award